

# LAND ROVER 110

## Heavy Duty 6 x 6



*Long Range Patrol Vehicle*



*Personnel/Cargo Vehicle towing 105 mm gun*



# LAND ROVER 110 Heavy Duty 6 x 6

ENGINE	ISUZU 4BD1 T
Type	4 Cylinder turbocharged direct injection diesel
Capacity	3.856 litres
Max. Power	90 kW @ 3000 r.p.m.
Max. Torque	314 Nm @ 2,200 r.p.m.
Alternator	12 volt x 70 amp output, belt driven from crankshaft, incorporating vacuum pump for braking system.
Injection System	Bosch in line type with combined pneumatic and mechanical governor.
Air Cleaner	Donaldson two stage dry element type with filter replacement indicator.
Exhaust System	Chassis mounted with single silencer discharging on right hand side of vehicle.
Cooling System	Cross flow radiator with expansion tank. Pressurised to 100 kPa.
Clutch	Single dry plate diaphragm spring 275mm ida.
Options	Supplementary 28 volt x 100 amp military alternator High level air intake Tyre pumping compressor

} DIN 70020 net

ENGINE	LAND ROVER 3.5 V8
Type	V8 aluminium petrol engine
Capacity	3.528 litres
Max. Power	100 KW @ 5000 r.p.m.
Max. Torque	253 Nm @ 2,500 r.p.m.
Alternator	12 volt x 45 amp output, belt driven from crankshaft.
Carburation	Twin SU carburettors
Options	12 volt x 65 amp alternator Supplementary 28 volt x 90 amp military alternator

} DIN 70020 net

GEARBOX/TRANSFER BOX	LAND ROVER LT95A
Type	4 speed heavy duty all synchromesh gearbox and 2 speed transfer box. Incorporates a lockable inter-axle differential plus a vacuum operated dog clutch to engage or disengage drive to the trailing axle via a fascia mounted switch.  The vehicle operates on-road in four wheel drive (to the front and centre axles), with six drive for cross country operation.
Ratios:	
Gearbox	1st 4.069:1    4th 1.000:1 2nd 2.448:1    Rev 3.664:1 3rd 1.505:1
Transfer Box	
- Diesel	High 0.996:1    Low 3.321:1
- Petrol	High 1.123:1    Low 3.321:1
Parking Brake	Mechanical 254mm dia drum brake fitted on rear of transfer box out shaft.

FRONT AXLE	LAND ROVER SPIRAL BEVEL
Type	Wide track fully floating spiral bevel steer/drive axle with heavy duty casing, enclosed outboard constant velocity joints, four pinion differential and high capacity driving head.
Capacity	1750 kg.
Ratio	4.70:1
Brakes	298mm dia disc front brakes with four piston callipers.

REAR AXLES	SALISBURY 8HA
Type	Wide track fully floating hypoid bevel drive axles with offset four pinion differentials.
Capacity	2050 kg/axle.
Ratio	4.70:1
Brakes	298mm dia disc rear brakes with four piston calipers.

CHASSIS & SUSPENSION	HEAVY DUTY 6 X 6
Frame	Hot dip galvanised tubular steel frame with welded box section crossmembers. Pressed steel front bumper.
Front Suspension	Axle located by leading arms and panhard rod and supported by long travel coil springs and telescopic dampers. 1750 kg capacity
Rear Suspension	Dual rate semi-elliptic leaf springs linked via shackles to a rubber bushed load sharing rocker beam. Axle movement is controlled by four long travel telescopic dampers and steel cable rebound straps. 4100 kg capacity.
Steering	Adwest power-assisted variable ratio worm and peg type 17.5:1 ratio - straight ahead. Left or right hand drive.
Brakes	Dual line vacuum hydraulic system.
Wheels and Tyres	Heavy duty steel disc 6.00 F x 16 - 7 off Steel belted radial ply tyres 7.50 R 16 LT x 8 ply - 7 off Spare wheel is located under chassis behind rear axle.
Fuel System	Twin 65 litre mid mounted fuel tanks with fillers in cabin side panels. Motorised fuel change over valve.
Battery	12 volt 98 amp hour low maintenance lead acid battery on carrier in engine compartment.
Options	Alternative wheels and tyres Rear towing pintle Helicopter slinging points Jerrycan stowage Chassis mounted tool boxes Chassis mounted vehicle recovery winch Chassis mounted radio batteries Tubular steel front brush guard Heavy duty brush guard with side bars

CAB	
Type	Wide, bonneted cab with hot dip galvanised steel space frame and aluminium alloy floor, back and wing panels. Steel framed bonnet with fibreglass skin. Cab painted with high durability polyurethane paint.
Trim	Fully trimmed doors, roof side and back panels. Sound proofing on toe boxes, seat box and floor panels.
Fittings	Three vinyl trimmed seats provided in cabin for driver and two passengers, all with fore/aft and rake adjustment. Inertia reel lap/sash seat belts fitted for outboard seating positions, with static lap belt for centre seat. Twin ventilation flaps in cabin front panel feeding full width louvres above fascia. Fibreglass fascia moulding with large storage compartment on passenger's side. High capacity heater/demister with fascia mounted controls. Twin sun visors, rear vision mirror and interior light mounted on cabin header panel.
Glass	Laminated flat glass windscreen with zone tinted upper band. Wind up windows in side doors. Twin opening rear quarter light windows fitted in cabin rear side panel. Sliding glass window fitted high on cabin back panel.
Controls	Column mounted waterproof switches for indicators, side and head lamps, horn, wipers and washers. Fascia mounted hazard warning, interior light/instrument light and heater blower switches. Heater directional controls and transfer box control switch mounted on fascia.
Instruments	Speedometer, fuel gauge, water temperature gauge, voltmeter and warning lamp module fitted in fibreglass moulded instrument binnacle - with provision for additional instrumentation if required.
Options	Two piece side doors with door pockets and sliding glass windows Fabric trimmed seats Cabin air conditioning Additional instrumentation Military lighting system Radio antenna mounts Roof Hatch Alternative body styles Disruptive pattern painting



Land Rover Australia offers this brochure as a general guide to product specifications of the Land Rover 110 6 x 6. All data presented in this brochure is believed to be correct as at May 1990. However, as development is an ongoing process, changes may occur from time to time which will not necessarily be reflected in this brochure. Therefore Land Rover Australia reserves the right to change specifications without notice. Accordingly, this brochure should not be regarded as an infallible guide to current specifications, nor does it constitute an offer for sale of any particular vehicle. Dealers and Distributors are not agents of Land Rover Australia, and have absolutely no authority to bind Land Rover Australia by any express or implied undertaking or representations.



# LAND ROVER 110 Heavy Duty 6 x 6

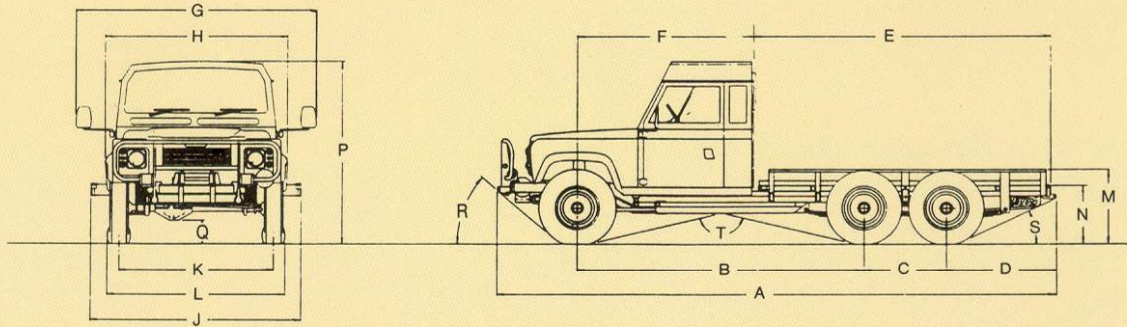

## NOMINAL DIMENSIONS

A	Overall Length	6001 mm
B	Intermediate Wheelbase	3040 mm
C	Rear Axle Spacing	900 mm
D	Rear Overhang	1183 mm
E	Cab Back to Rear Crossmember	3147 mm
F	Front Axle to Cab Back	1925 mm
G	Width Over Mirrors	2430 mm
H	Width Over Front Wings	1980 mm
J	Width Over Rear Crossmembers	2062 mm
K	Track - Front and Rear	1698 mm
L	Width Over Tyres - Front and Rear	1910 mm
M	Body Mounting Height	- Unladen 920 mm - Laden 840 mm
N	Rear Crossmember Heights	- Unladen 780 mm - Laden 700 mm
P	Cab Height	- Unladen 2080 mm - Laden 2050 mm
Q	Axle Ground Clearance	215 mm
R	Approach Angle	- Unladen 45° - Laden 41°
S	Departure Angle	- Unladen 33° - Laden 30°
T	Ramp Angle	- Unladen 148° - Laden 152°
	Turning Circle	- Wall to Wall 17.2 m - Kerb to Kerb 16.8 m

## MASS DATA

Unladen Mass - Basic Chassis Cab*	2600 kg
- Military Chassis Cab**	3100 kg
Gross Vehicle Mass	5600 kg
Gross Combination Mass	7100 kg

\* Diesel engined chassis cab vehicle without military equipment but with full capacity of water, oil and fuel plus spare wheel and tyre.

\*\* Australian Army specification chassis cab vehicle without rear body, seats and canopy, but with full military equipment including 24 volt supplementary electrical system, winch, driver and full capacity of water, oil and fuel (including jerry cans) plus spare wheel and tyre.

## DERIVATIVES

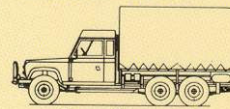

Cargo/Personnel

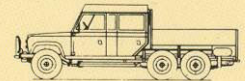

Crew Cab

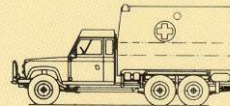

Ambulance

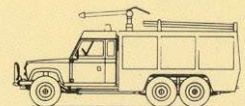

Fire Truck



Shelter Transport

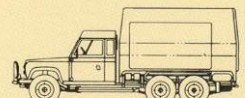

Maintenance Vehicle

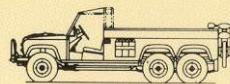

Patrol Vehicle

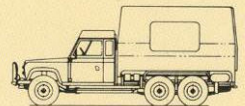

Command Post

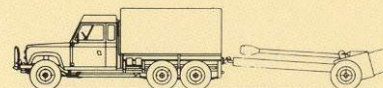

Gun Tractor



Air Defence Vehicle

## PERFORMANCE DATA

Maximum Speed - Diesel engine	100 km/h
- Petrol engine	115 km/h
Range (on tanks) - Diesel engine	600 km
- Petrol engine	450 km
Gradeability - Stop and Restart at G.V.M.	60%
Overturn Angle - Unladen Cargo Vehicle	40°



A wide variety of specialised body configurations can be made to order.



**LAND ROVER** 110 Heavy Duty 6 x 6



*Ambulance*



*Lightweight Helicopter Transportable Vehicle*





*Electronic Repair Vehicle*

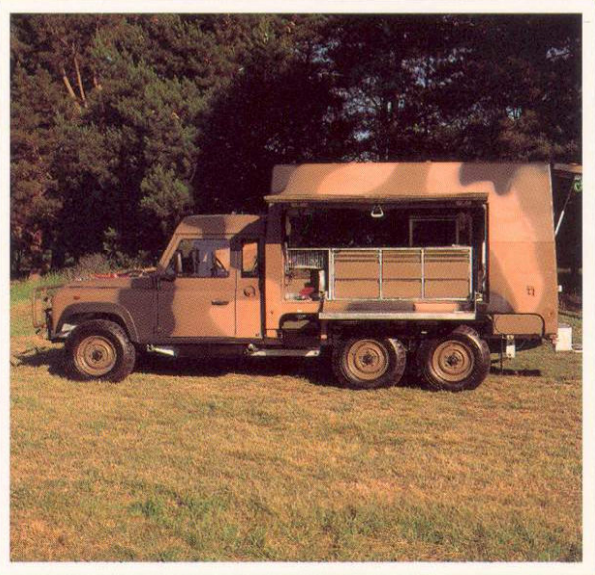

*General Maintenance Vehicle*



*Air Defence Vehicle (towing Rapier)*



*Personnel/Logistics Vehicle*



*Interior Electronic Repair Vehicle*



# LAND ROVER 110 Heavy Duty 6 x 6

The Land Rover 6 x 6 was originally developed to meet the requirements of the Australian Army for a 2 tonne payload cross country vehicle. Extensive performance, durability, climatic and user trials were conducted by the Australian Army against international competition, leading to the selection of Land Rover 4 x 4 and 6 x 6 vehicles for volume production.

The 6 x 6 vehicle is adaptable to a wide range of specialised military and civilian roles. Currently approved Australian Army derivatives comprise Cargo/Personnel Carrier, Air Defence Vehicles (Rapier and RBS70), Ambulance, General Repair and Electronics Repair Vehicles and a Long Range Patrol Vehicle. Other variants have been developed or are under investigation including Crew Cab, Command Post, Communications, Logistics, Recovery and Fire Fighting Vehicles.

The vehicle has been designed to accept either the Isuzu 4BD1T turbocharged diesel or Land Rover's V8 petrol engine in right or left hand drive. A range of options are available which permits the vehicle to be built to a customer's individual requirements.

Some of the major features of the Land Rover 6 x 6 vehicle are:

- High payload carrying capability. (The basic chassis cab vehicle provides an allowance of 3.0 tonnes for optional fittings and equipment, rear body, payload and crew).
- Low rear chassis height.
- All derivatives are air transportable in a C130 Hercules – 2 per aircraft – without preparation. This includes the Ambulance and Maintenance vehicles with modular rear bodies.
- High level of corrosion resistance (both the chassis frame and cab frame are hot dip galvanised, while extensive use is made of aluminium and galvabond panels).
- High standard of cross country mobility, ride and stability.
- Easy rear body fitment (bodies can be attached directly to the Land Rover's rigid rear chassis).
- Rear body interchangeability (the modular rear bodies share common mounting arrangements with the more basic Cargo/Personnel or Air Defence rear bodies).
- High spare parts and servicing compatibility with other Land Rover vehicles.
- All Australian Army vehicles are fully NATO codified.

The Land Rover 6 x 6 has been developed by Land Rover Australia (a division of JRA Limited) with full support from Land Rover Limited. It is available through Land Rover's worldwide distribution network with full sales and service support.

For further information contact:

**Land Rover Australia**  
(a division of JRA Limited)  
P.O. Box 59,  
Liverpool  
NSW 2170  
Australia

Telephone: 61 2 600 1333  
Facsimile: 61 2 600 8935  
Telex: AA 12022



**Land Rover Limited,**  
Lode Lane,  
Solihull,  
West Midlands B92 8NW  
England

Telephone: 44 21 722 2424  
Facsimile: 44 21 742 5012  
Telex: 338641 LANROV G  
Cables: LANROV SOLIHULL.